

**TASMAN SERIES  
DRUM WINCH**

© Copyright: VETUS-Maxwell APAC Ltd.

All rights reserved

VETUS-Maxwell APAC Ltd. reserves the right to make engineering changes to all products without notice. Illustrations and specifications not binding as to detail.

**P103181 Rev.2.00**

30/05/18

Printed in New Zealand

# Contents

1.0	INTRODUCTION.....	2
1.1	PRE-INSTALLATION NOTES.....	2
1.2	IMPORTANT INFORMATION .....	2
1.3	SPECIFICATIONS .....	3
1.4	ROPE AND CHAIN SELECTION .....	4
2.0	INSTALLATION.....	5
2.1	SELECTION OF POSITION FOR THE DRUM WINCH.....	5
2.2	INSTALLATION PROCEDURE .....	5
2.2.1	ADJUSTING MOTOR/GEARBOX ANGLE .....	6
2.3	WIRING INSTRUCTIONS.....	8
2.4	POWER CONNECTIONS TO DC MOTOR.....	8
2.5	FITTING ROPE / CHAIN .....	9
2.6	CORROSION PROTECTION.....	9
2.7	CHAIN COUNTER FITMENT.....	9
3.0	OPERATION .....	10
3.1	PERSONAL SAFETY WARNINGS .....	10
3.2	OPERATING THE DRUM WINCH.....	10
3.3	EMERGENCY OPERATION.....	11
4.0	MAINTENANCE.....	12
4.1	DRUM WINCH MAINTENANCE.....	12
4.2	RECOMMENDED LUBRICANTS .....	12
5.0	TROUBLESHOOTING.....	13
	APPENDIX A - Dimensional Drawings.....	14
	APPENDIX B – Spare Parts.....	15
	APPENDIX C – DC Electric Wiring .....	18
	APPENDIX C – Mounting template (NOT TO SCALE).....	20

## 1.0 INTRODUCTION

### 1.1 PRE-INSTALLATION NOTES

- Read this manual thoroughly before installation and/or using the drum winch. Failure to adhere to the correct procedures, recommendations and guidelines described in this Owner's Manual may invalidate the warranty.
- Correct selection of drum winch together with correct installation, care in use and maintenance, are essential for long life and reliable performance.
- In addition to this instruction manual, the following components should be included with the drum winch:
  - Drum Winch
  - Solenoid
  - Remote up/down control panel
  - Circuit breaker /isolator panel
  - Deck Cutout Details (at rear of manual)
  - Motor Bolt Kit
    - Bolts (x 2)
    - Spring Washers (x 2)
  - Rope and Chain (fitted to drum)
  - Mounting Kit
    - Bolts (x 6)
    - Nuts (x 6)
    - Flat washers (x 6)
    - Spring washers (x 6)

### 1.2 IMPORTANT INFORMATION

- The TASMAN 8 Drum winch is designed for up to 8mm chain and up to 25kg anchors.
- The TASMAN 6 Drum winch is designed for up to 6mm chain and up to 16kg anchors.
- When purchasing an anchor make sure it fits into the bow roller and is self-launching.
- Do not use the drum winch as the mooring point if you are staying at an anchorage for an extended period of time e.g. overnight.
- Keep hands, feet, loose clothing and hair well clear of the drum winch and rope/chain during operation.
- Never operate the drum winch from a remote station without having a clear view of the drum winch.
- Ensure there are no swimmers or divers nearby when dropping anchor.
- Do NOT use the drum winch to pull the boat forward when raising the anchor. Use the boat's engine to drive the boat up to the anchor.
- Do NOT attempt to break free a fouled anchor with the drum winch. Secure the rope/chain to a bollard or cleat and use the boat's engine to break the anchor out.
- Always firmly secure the anchor when under way or in heavy seas. Do not rely on the drum winch as a securing device.
- Always turn the circuit breaker/isolator switch off when the drum winch is not in use and before you leave the boat.
- When using the drum winch DO NOT switch immediately from one direction to the other without first waiting for the winch to stop as this could damage the winch.
- Do NOT operate drum winch whilst under the influence of alcohol or drugs

**Failure to adhere to these safety precautions may result in voiding of warranty.**

## 1.3 SPECIFICATIONS

TASMAN 6-6		
Electric Motor	:	DC Motor
Motor power	:	600W
Voltage	:	12v or 24v
Max Pulling Force (1 layer on drum)	:	700kg
Max Pulling Force (Full drum)	:	100kg
Haulage Speed (Full drum)	:	50m/min
Haulage Speed (1 layer on drum)	:	7.5m/min
Rope Size	:	6mm Drumwarp x 70m
Chain Size	:	6mm Short Link DIN766 x10m
Net Weight (Incl rope/chain)	:	24kg
TASMAN 6-4		
Electric Motor	:	DC Motor
Motor power	:	600W
Voltage	:	12v or 24v
Max Pulling Force (1 layer on drum)	:	700kg
Max Pulling Force (Full drum)	:	100kg
Haulage Speed (Full drum)	:	50m/min
Haulage Speed (1 layer on drum)	:	7.5m/min
Rope Size	:	4mm Drumwarp x 100m + 6mm Drumwarp x 10m
Chain Size	:	6mm Short Link DIN766 x10m
Net Weight (Incl rope/chain)	:	25kg
TASMAN 8-8		
Electric Motor	:	DC Motor
Motor power	:	1000W
Voltage	:	12v or 24v
Max Pulling Force (1 layer on drum)	:	1000kg
Max Pulling Force (Full drum)	:	350kg
Haulage Speed (Full drum)	:	60m/min
Haulage Speed (1 layer on drum)	:	13m/min
Rope Size	:	8mm Drumwarp x 100m
Chain Size	:	8mm Short Link DIN766 x10m
Net Weight (Incl rope/chain)	:	37kg
TASMAN 8-6		
Electric Motor	:	DC Motor
Motor power	:	1000W
Voltage	:	12v or 24v
Max Pulling Force (1 layer on drum)	:	1000kg
Max Pulling Force (Full drum)	:	350kg
Haulage Speed (Full drum)	:	60m/min
Haulage Speed (1 layer on drum)	:	13m/min
Rope Size	:	6mm Drumwarp x 150m
Chain Size	:	6mm Short Link DIN766 x10m
Net Weight (Incl rope/chain)	:	31kg

## 1.4 ROPE AND CHAIN SELECTION

- Use of the correct type of rope is essential for the drum winch to operate properly and without jams.

### **DRUM CAPACITY**

The Tasman drum winch is pre fitted with rope and chain from the factory. Depending on the version the drum winch will be fitted with either

- 10m 6mm chain with 70m 6mm Drumwarp rope
- 10m 6mm chain with 10m 6mm Drumwarp rope with 100m 4mm Drumwarp rope
- 10m 8mm chain with 100m 8mm Drumwarp rope
- 10m 6mm chain with 150m 6mm Drumwarp rope

When replacing the rope/chain ensure the total length of the rope will not exceed the drum capacity, drum capacity will change with rope and chain diameter.

Maxwell recommends braided rope specifically made for drum winches, this rope has medium stretch high strength properties in a firm small diameter profile which make it ideal for anchoring and laying on the drum winch.

Maxwell do not recommend 3 strand or 8 braid ropes for the drum winch as they typically have a very soft layup which can cause the rope to bury into the rope already laid on the drum when the anchoring load increases, these ropes also have a lower strength to volume ratio which means less rope can be loaded onto the drum.

## 2.0 INSTALLATION

### 2.1 SELECTION OF POSITION FOR THE DRUM WINCH

Plan location carefully:

1. Ensure the drum winch is positioned exactly on the centreline of the bow roller and rotation axis perpendicular to centreline to ensure correct stowing of rope/chain onto drum.

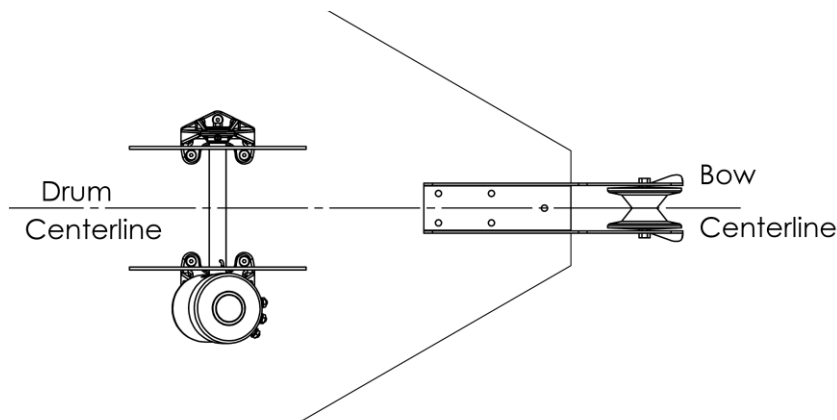

2. Ensure the rotation of the gearbox is correct (ref pg5), if necessary the gearbox can be run in the reverse direction however the Maximum holding load is reduced to 1500kg (from 2000kg)
3. Ensure the deck is flat. If not; install plinth to ensure the drum winch sits on a flat surface.
4. Ensure the mounting area is of appropriate strength to accommodate loads applied by drum winch/anchor and chain.
5. The drum winch must be positioned to allow the rope/ chain to have a clear run from the bow roller to the drum
6. The bow roller should have a central groove suitable for the chain size.
7. The rope/chain must be able to feed onto the full width of the drum with no obstruction, ensure the bow roller side plates and/or deck opening do not foul the rope.

Consult your boat manufacturer if you have any doubt about strength or suitability of the mounting location.

For unusual installations please contact your Maxwell representative for advice

### 2.2 INSTALLATION PROCEDURE

Use the Deck Mounting template, as a guide for marking and drilling the holes.

**Tip:** On GRP boats, running the drill in reverse first will reduce chipping of the gel coat.  
On GRP or wooden decks, seal the edges of the holes with epoxy to avoid ingress of moisture.

- Before drilling the holes in the deck check all under deck clearances. Read and understand installation instructions contained within this manual.
  - Make sure your printout of the deck template is correctly scaled.
  - VETUS-Maxwell is not responsible for any inaccurate data due to reproduction errors of fax machines, printers, photocopiers etc.
1. Use the Cut-Out Template, as a guide for marking and drilling the holes.
  2. Make sure the template is positioned so that the drum is positioned centrally to the bow roller.
  3. Mark out the desired position for the holes.
  4. Using drill start drilling holes

5. Seal the edges of the hole with epoxy to avoid ingress of moisture. (Not required for steel or aluminium.)
6. Align the holes in drum brackets with the holes cut into deck and fasten the drum support legs to the deck using screws, washers and nuts.

Tighten the nuts progressively and evenly. Make sure the installation is firm, but do not over tighten the nuts. Do not use power tool.

### 2.2.1 ADJUSTING MOTOR/GEARBOX ANGLE

\* If required, the gearbox angle and therefore the motor fitment position can be adjusted to suit the installation

There are 18 possible positions for the motor, the angle can be adjusted in 15° increments.

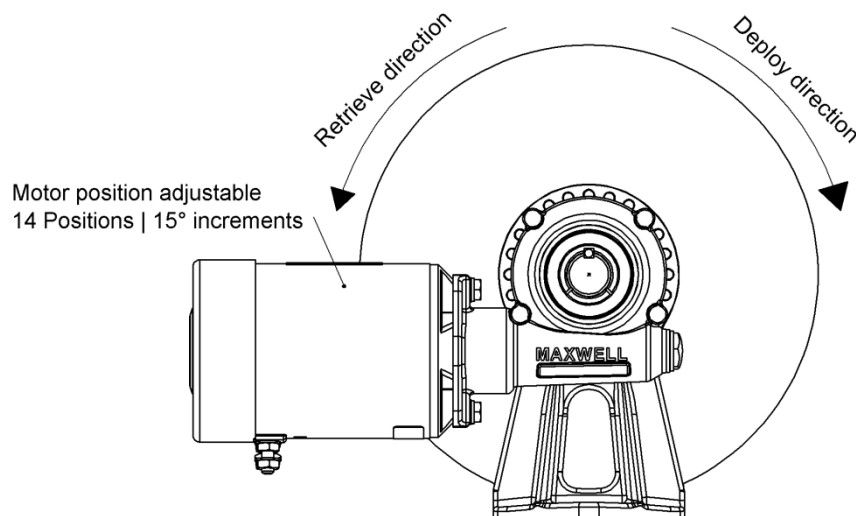



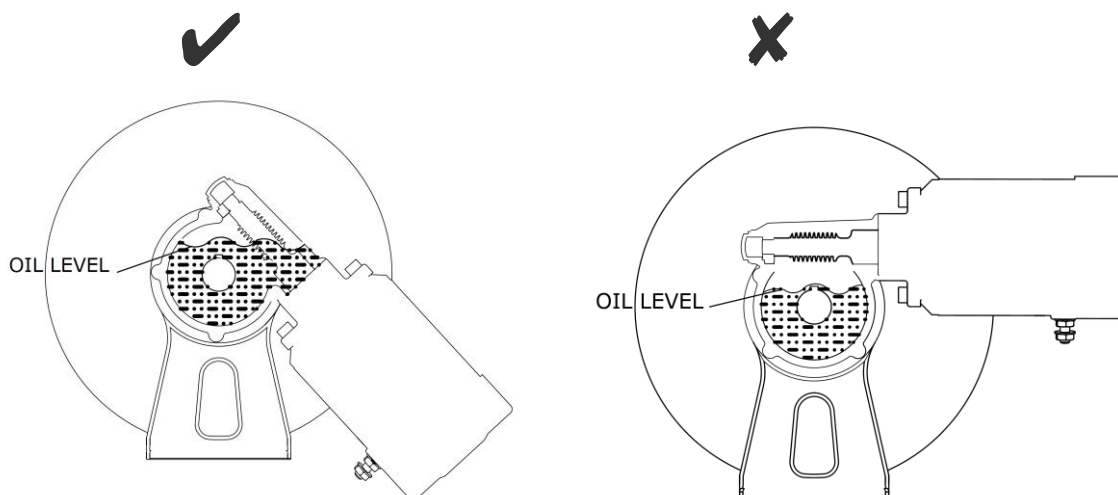

#### Retrieve

To ensure gearbox durability, position motor so that the input gear is at least partially covered with oil.

Note: The diagram below has the drum winch mounted to the deck horizontally, if the drum winch is mounted to the vertical bulkhead the acceptable motor positions change accordingly.

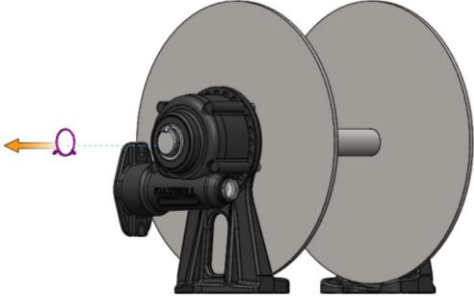
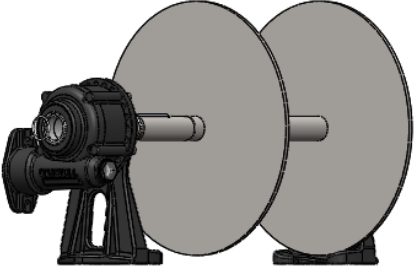

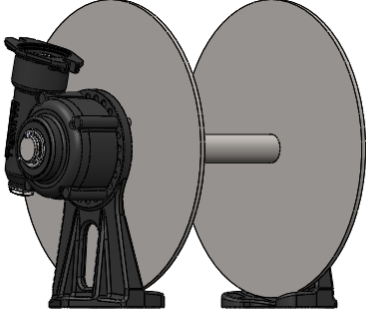

<p>1. Remove circlip and key</p>	<p>2. Slide gearbox from shaft</p>
	
<p>3. With the gearbox laid flat (output shaft facing vertical) remove the 4 x M6 cap screws securing the leg support. (With the 4 screws removed the gearbox halves are able to separate take caution no to spill oil)</p>	<p>4. Separate the gearbox case and leg support, rotate gearbox to desired position. (Full separation of the two cases is not necessary only enough to break the seal)</p>
	
<p>5. Apply locktite to the 4 x M6 cap screws, refit and torque to 7Nm</p>	<p>6. Assemble in reverse order</p>
	

## 2.3 WIRING INSTRUCTIONS

Installation must be carried out in accordance with USCG, ABYC, NMMA or other relevant local electrical requirements.

We recommend that connection of the power lines and control circuitry to the drum winch be done by qualified technician, to ensure reliable and safe operation of the drum winch.

After all connections have been made and system tested, seal terminals against moisture by spraying with: CRC2043 "Plasti-Coat", CRC3013 "Soft Seal" or CRC2049 "Clear Urethane".

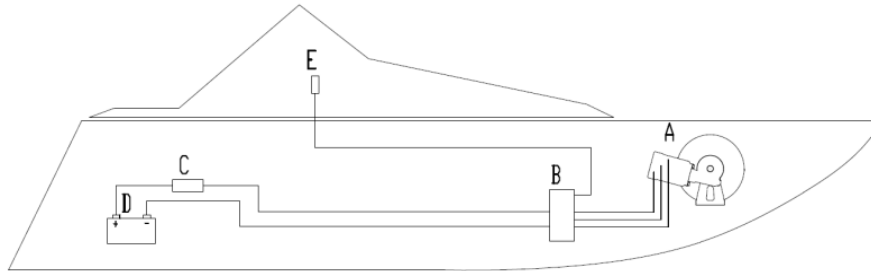

Solenoid pack (Required and included)

The solenoid pack (B) should be located in a dry area close to the drum winch.

Circuit breaker/isolator (Required and included)

TASMAN 6 - 12V-80amp | 24V-40Amp

TASMAN 8 – 12V -135amp | 24V 80Amp

**! FOR SAFETY - The drum winch circuit requires protection provided by an isolator switch and either a fuse or circuit breaker.**

Position the circuit breaker/isolator (C) no further than 1.8 m (6 ft) away from the battery (D) in an accessible and dry location.

Remote control panel (Recommended)

The remote control panel (E) should be mounted in a convenient location (such as the bridge, helm or cockpit) so that the operator can see the drum winch.

## 2.4 POWER CONNECTIONS TO DC MOTOR

See Table 2.1 to select the appropriate cable size for power supply. The recommendation assumes that the cable insulation has a minimum temperature rating of 90°C and sizes allow for a maximum 10% voltage drop over the total length.

Cable lengths given are from the battery terminal to the terminal on the motor, via the solenoid box, and then back to the battery.

After connecting the cables, spray all terminals with anti-corrosive waterproof coating, "CRC 3013 Soft Seal" or equivalent.

Cable Length	12V System		24V System	
	Cable Size		Cable Size	
	mm <sup>2</sup>	AWG	mm <sup>2</sup>	AWG
TASMAN 6 600w motors				
Up to 10m (35')	16	6	4	10
10m - 20m (35' - 65')	25	4	6	8
20m - 28m (65' - 91')	35	2	10	8
TASMAN 8 1000w motors				
Up to 10m (35')	25	4	10	6
10m - 20m (35' - 65')	35	2	10	6
20m - 28m (65' - 91')	50	0	16	4

Table 2.1  
Recommended cable sizes

### Motor Cable connections

When tightening the cables to the motor, ensure the lower nut (A) is secure against turning when tightening the upper nut (B). This will prevent damage occurring within the motor

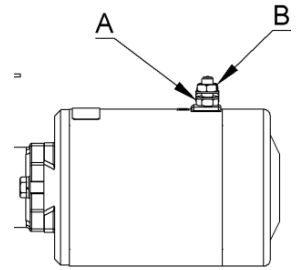

## 2.5 FITTING ROPE / CHAIN

The TASMAN drum winch is shipped with the rope/chain pre-fitted to the drum.

If for any reason the rope/chain must be removed or replaced then the tail end of the rope should be looped through the provided eyelet around and secured to the shaft. The provided eyelet is to prevent the rope slipping on the shaft and should not be subjected to anchoring loads should the rope/chain be fully deployed.

## 2.6 CORROSION PROTECTION

Once installed spray all exposed electrical connections and motor body with anti-corrosive waterproof coating, "CRC 3013 Soft Seal" or equivalent.

## 2.7 CHAIN COUNTER FITMENT

All Maxwell chain counters except the AA150 can be configured to work with drum winches, after setting the total rode length and the drum diameter (TASMAN 6 = Ø200 | TASMAN 8 = Ø300mm) the counter will calculate the distance per drum revolution accounting for the change in working diameter as the drum empties / fills.

Due to stretch in the rope and variability in the way the rope/chain feeds onto the drum the counter cannot be 100% accurate however is typically within  $\pm 10\%$  of actual.

To fit the chain counter the optional chain counter fitting kit (P90022) must be assembled to the drum winch, although this can be done with the drum in place it is easier to perform this before the drum winch is fitted to the boat.

Full instructions on fitting the chain counter are included with the fitting kit.

## 3.0 OPERATION

### 3.1 PERSONAL SAFETY WARNINGS

- As with all load carrying equipment, the consequences of heavy overload, neglect or misuse may be unexpected failure and exposure of crew and/or vessel to risk. Operate the drum winch with extreme care at all times.
- Before testing the drum winch for the first time, check that all the wiring has been done correctly.
- When using the drum winch at all times practice good seamanship and adhere to the following rules in order to avoid any likelihood of injury or accident.
- Run the vessels engine whilst using the drum winch. This is not only a safety precaution but also helps minimise the drain on the batteries.
- Do not use drum winch as a bollard or mooring point. When at the anchor, always tie off directly to a bollard or sampson post.
- At all times keep hands, feet, loose clothing, cordage, your hair and other people on board WELL CLEAR.
- When the drum winch is not in use, make sure the power supply is isolated, making an accidental operation thereby impossible.
- The circuit breaker/isolator provides high current protection for the main supply cables as well as the means to isolate the circuit.

### 3.2 OPERATING THE DRUM WINCH

#### Lowering the Anchor

- Engage circuit breaker
- Operate the drum winch by pressing the toggle switch down on the remote up/down control panel to pay out the rope/chain
- Ensure the rope/chain has sufficient load on it to prevent the drum from overrunning.
- Pay out sufficient rope/chain to set the anchor. Keep tension on rope as any slack in the rope may cause the drum to overrun and tangle the rode
- Watch as the rope/chain is being fed out. Any jam might cause damage to the drum winch
- When anchor is set disengage the circuit breaker to prevent accidental activation of the drum winch.

#### Raising the Anchor

- Engage circuit breaker
- Operate the drum winch by pressing the toggle switch up on the remote up/down control panel .
- Motor up to the anchor while retrieving it. Do not use the drum winch to pull the boat to the anchor.

**TO AVOID DAMAGING THE BOW FITTING, RETRIEVE THE LAST METER (3') OF ROPE/CHAIN SLOWLY AND TAKE CARE WHEN DOCKING THE ANCHOR.**

- Disengage the circuit breaker to cut power to drum winch

DO NOT use the drum winch to secure the anchor into the bow roller. Use an appropriate tensioner or snubber.

### 3.3 EMERGENCY OPERATION

If the drum winch fails to operate due to electrical or mechanical fault the anchor can be lowered manually

#### Lowering the Anchor manually

- Temporarily secure the anchor.
- Remove the spring clip from gearbox end of shaft.

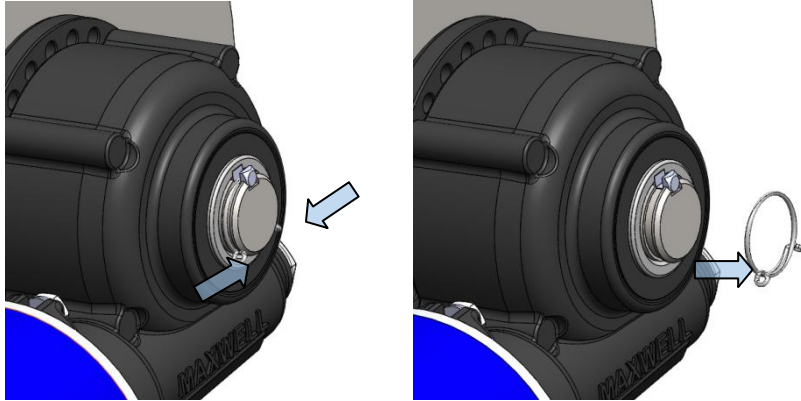

- Remove the key from shaft, the spring clip can be used to assist.

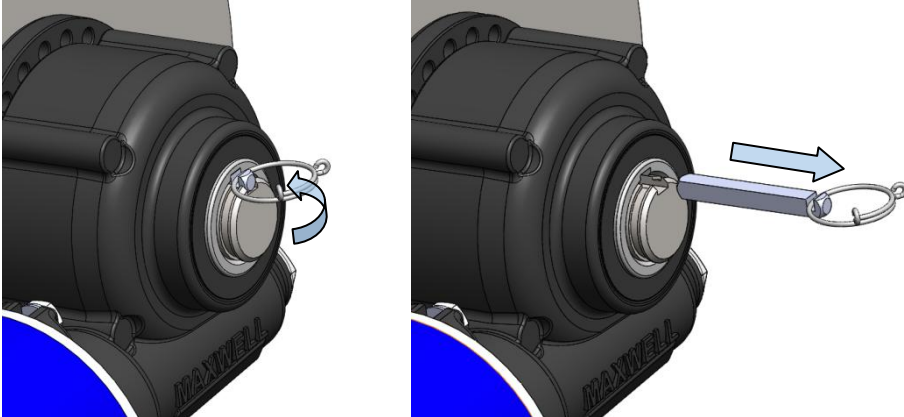

- Spray lubricant into the shaft keyway to lubricate the shaft inside the gearbox.
- Ensure all body parts are clear of the anchor chain/rope and drum winch drum.
- Release the anchor and lower anchor by hand or allow unit to free fall.
- Once sufficient chain/rope has been deployed to set the anchor secure the rope to a bollard or similar hard point, alternatively the key can be reinserted into shaft/gearbox and spring clip fitted.

#### Raising the Anchor

- Haul the anchor by hand, either stow the rope/chain loosely into the locker or wind manually onto the drum.
- Secure the anchor into the bow roller or stow onboard.

NOTE! After using the emergency free fall feature it is recommended to remove the shaft from gearbox, clean, inspect and reapply anti-seize which may have been displaced during use.

## 4.0 MAINTENANCE

### 4.1 DRUM WINCH MAINTENANCE

#### Every Trip

- Wash down drum winch with fresh water

#### Every 3 Months

- Clean the Drum winch with a cloth damp with Kerosene (paraffin). Spray with CRC3097 “Long Life” or alternatively, CRC6-66 or WD40. Polish off with a clean non-fluffy cloth.
- Check tightness of all fasteners.

#### Every Year.

- The motor should be serviced by a qualified technician
- Remove any rust build up from the casing and paint with a suitable coating

#### Every 3 Years

- The gearbox should be inspected for damage to the seals, and replace as necessary

! Failure to carry out the maintenance and service, as described herein, will invalidate warranty.

! Before doing any maintenance work on the electric motor and wiring, make sure the power supply is switched off and isolated.

! Use synthetic oils only. Never mix two oils, even if they are from the same manufacturer.

#### **WARNING:**

When re-assembling care must be taken to ensure the key is properly seated in the shaft.

DO NOT wrap the motor with grease cloth as this prevents the cooling of the motor.

### 4.2 RECOMMENDED LUBRICANTS

#### **Greases**

Lithium complex based grease with a consistency between NLGI consistency No.1 & No. 2

#### **Gearbox Oil**

Capacity: 90 – 100ml (3.0 – 3.4 fl oz)

Grade: API GL-4 or lower (low sulphur)

Viscosity: 90 to 110 weight

#### **Anti-Corrosive Coatings**

- CRC 3013 Soft Seal
- Boeshield T9
- Lanocote

#### **Anti-Seize Coating**

- International Paints                      Res-Q-Steel

! Never mix greases, use only one type. If in doubt, remove the previous lubricant and clean the parts thoroughly before applying the new one.

## 5.0 TROUBLESHOOTING

<b>Problem</b>	<b>Possible Cause</b>	<b>Solution</b>
Drum winch does not rotate.	No electric power to controls.	<p>Make sure the isolator switch for the drum winch controls is ON.</p> <p>Check the fuse on power supply to controls.</p> <p>If there is more than one type of control (pendant unit, footswitch, helm switch), check them all in an effort to isolate the problem</p> <p>Check the power supply to controls from the source, step by step, and identify the point where it stops.</p>
	Incorrect, incomplete or damaged wiring.	Check wiring against diagrams supplied.
	No power supply to the drum winch.	Check power supply lines. Check main isolator switch.
Drum winch is not able to pull the specified load.	Motor voltage does not match the power supply on board.	Check name plate on the motor. If confirmed, contact Maxwell.
Motor stops after prolonged heavy use.	The motor has been overloaded and has reached its maximum operating temperature.	Leave it to cool down and reset the circuit breaker.

# APPENDIX A - Dimensional Drawings (TASMAN 8)

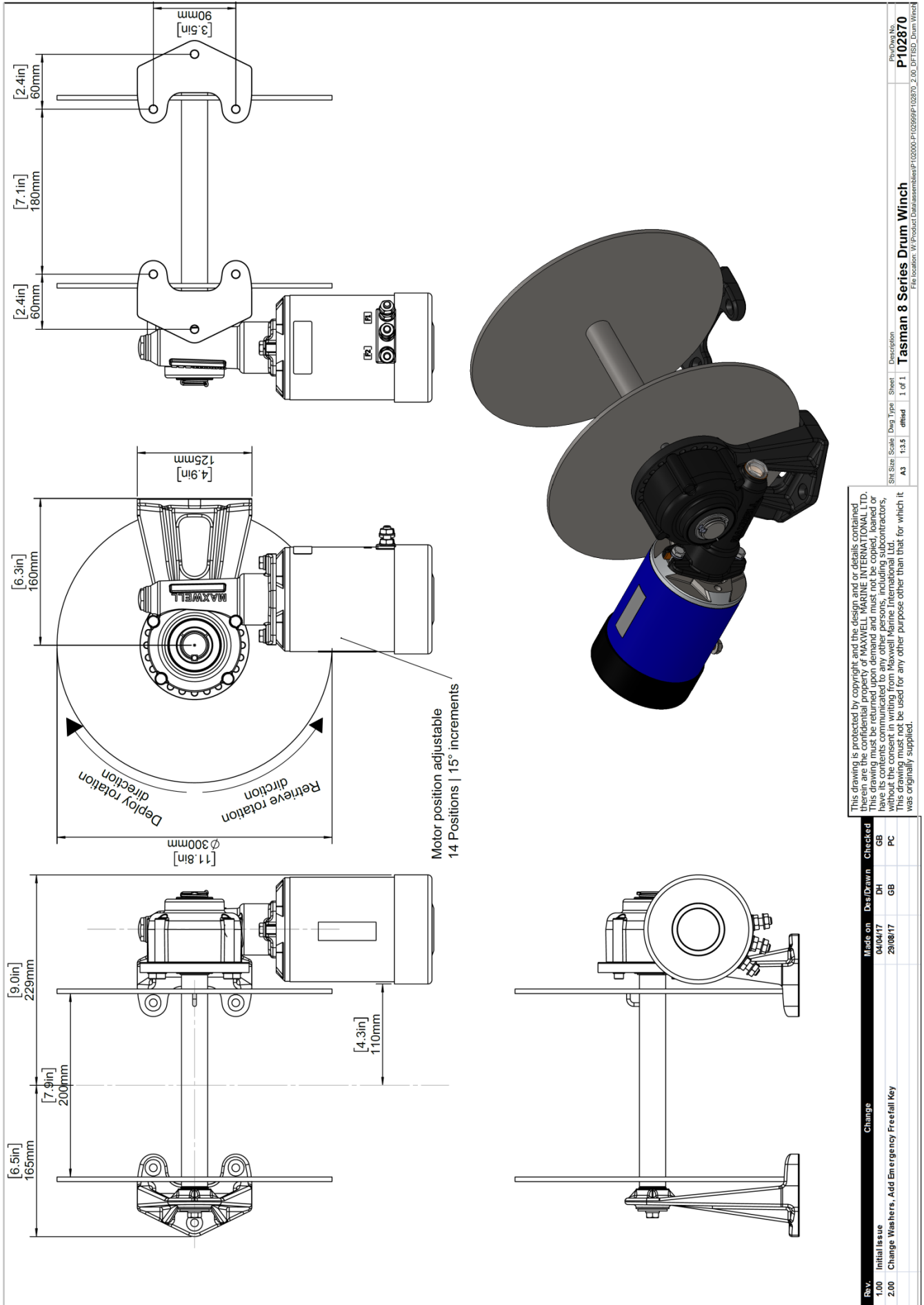

This drawing is protected by copyright and the design and details contained herein are the property of Maxwell Marine International Ltd. This drawing must be returned upon demand and must not be copied, loaned or have its contents communicated to any other persons, including subcontractors, without the consent in writing from Maxwell Marine International Ltd. This drawing must not be used for any other purpose other than that for which it was originally supplied.

Rev.	Change	Made on	Des/Drawn	Checked
1.00	Initial Issue	04/04/17	DH	GB
2.00	Change Washers, Add Emergency Freefall Key	29/08/17	GB	PC

Part No. **P102870**  
 Description: **Tasman 8 Series Drum Winch**  
 Sheet: 1 of 1  
 Scale: 1:3.5  
 Dwg Type: dfted  
 File location: W:\Product Data\assemblies\P102870-P102870-2.00\_DFTED\_Drum Winch



- Dimensional Drawings (TASMAN 6)

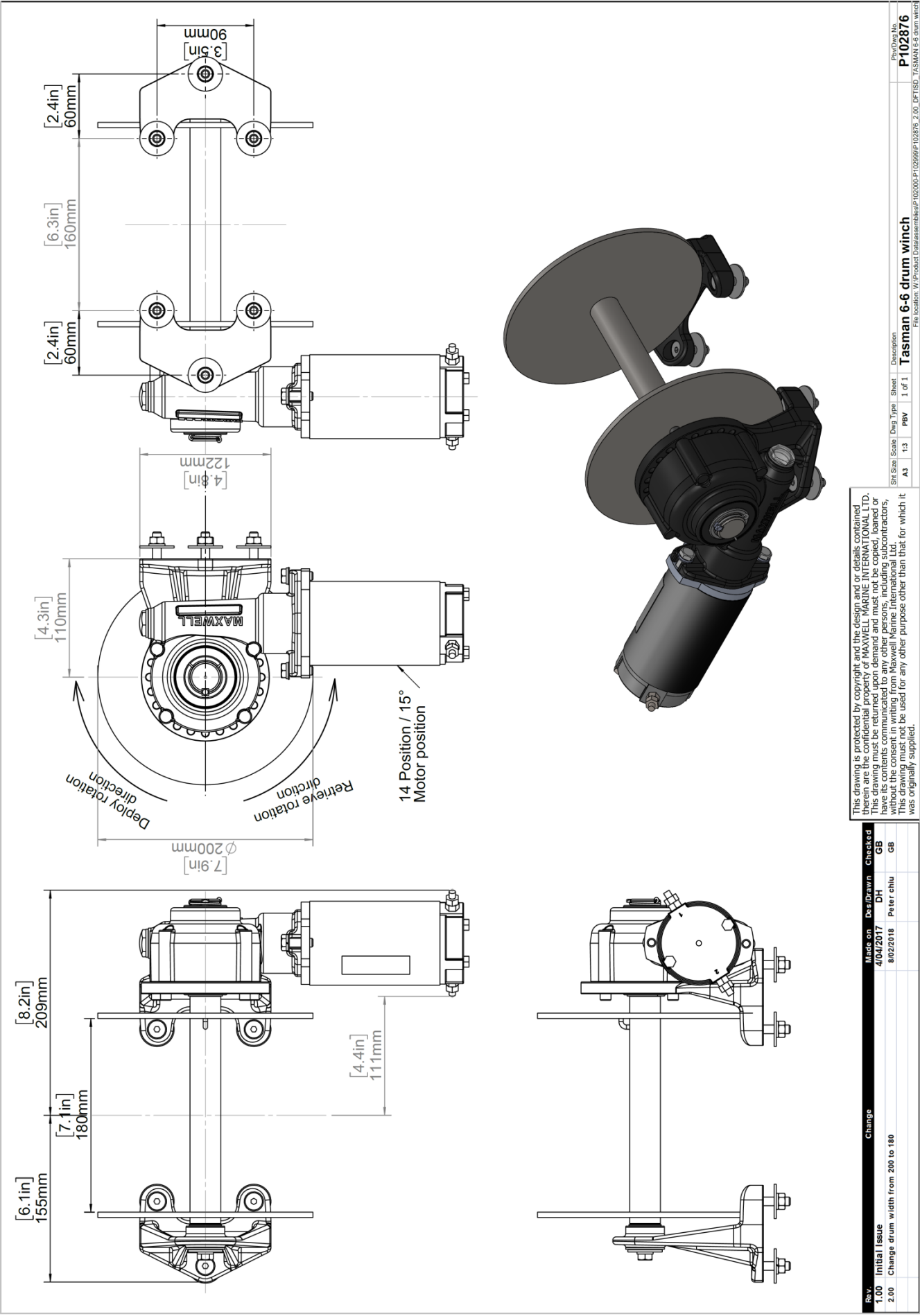

This drawing is protected by copyright and the design and or details contained therein are the confidential property of MAXWELL MARINE INTERNATIONAL LTD. This drawing must be returned upon demand and must not be copied, loaned or have its contents communicated to any other persons, including subcontractors, without the written consent of Maxwell Marine International Ltd. This drawing must not be used for any other purpose other than that for which it was originally supplied.

Rev.	Initial Issue	Change	Made on	By/Drawn	Checked
1.00			4/04/2017	DH	GB
2.00	Change drum width from 200 to 180		8/02/2018	Peter chiu	GB

File location: W:\Product Databases\MaxP102876-P102876-2.00\_DFT\ISO\_TASMAN 6-6 drum winch

Part No. No. **P102876**

Sheet 1 of 1

Rev A3

Scale 1:3

Drawn PEB

Checked

# APPENDIX B – Spare Parts (TASMAN 8)

PartNo	DESCRIPTION	P102870 /QTY.
P104164	Gearbox assy	1
P12072	Motor 12V 1000W	1
P12487	Kit- Motor bolt DC	1
3597	Flat Washer M8 x32 x2	7
4547	Quick Change Clip	1
8183	Supporting Bracket_Drum Winch_Machined	1
8184	Drum_Drum Winch	1
8296	Maxwell label	1
8404	Slotted Key 1/4' x 1/4' x 57mm_Drum Winch	1
SP0206	Set Screw Hex Hd M8 x 16	1
SP0366	Nut Hex - M8 SS	6
SP0467	Washer - Spring - M8 SS304	7
SP0878	Circlip External 1 1/8"	1
SP3712	Screw CSK Soc M8 x 35 SS316	6
SP3931	Bearing_IGUS Bush GFM-2023-21	1
SP3948	Thrust Washer	1

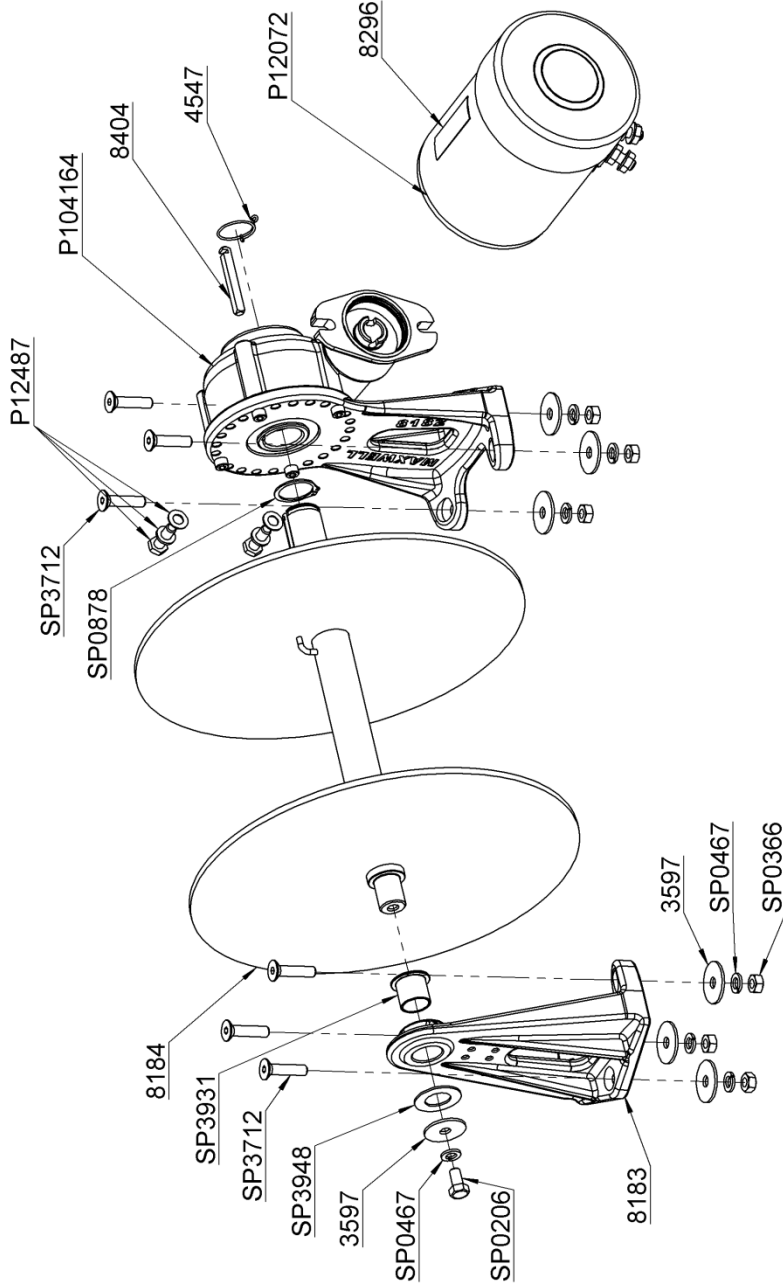

Copyright Maxwell Marine International

Rev.	Change	Made on	Des/Dwn	Checked
1.00	Initial issue	04/04/17	DH	GB
2.00	Change key to slotted key, back circlip to quick change clip.	29/05/17	Peter Chiu	GB

Sht Size	Scale	Dwg Type	Sheet	Description
A4	1:5	pbv	1 of 2	<b>Drum Winch</b>

File location: W:\Product Data\assemblies\P102000-P102999\P102870\_200\_pbv\_Drum Winch

Pbv/Dwg No.  
**P102870**

# Spare Parts (TASMAN 6)

PartNo	DESCRIPTION	P102876 /QTY.
3597	Flat Washer M8 x32 x2	7
4547	Quick Change Clip	1
8296	Maxwell label	1
8404	Slotted Key 1/4' x 1/4' x 57mm_Drum Winch	1
8422	Drum_TASMAN 6 Ø200x180	1
8424	Support Bracket_TASMAN 6_Machined	1
P10068	DC motor	1
P12487	Kit - Motor Bolt DC	1
P104165	Gear Box_Tasman 6-6 drum winch	1
SP0206	Set Screw Hex Hd M8 x 16	1
SP0366	Nut Hex - M8 SS	6
SP0467	Washer - Spring - M8 SS304	7
SP0878	Circlip Exteral 1 1/8"	1
SP3712	Screw CSK Soc M8 x 35 SS316	6
SP3931	Bearing_IGUS Bush GFM-2023-21	1
SP3948	Thrust Washer	1

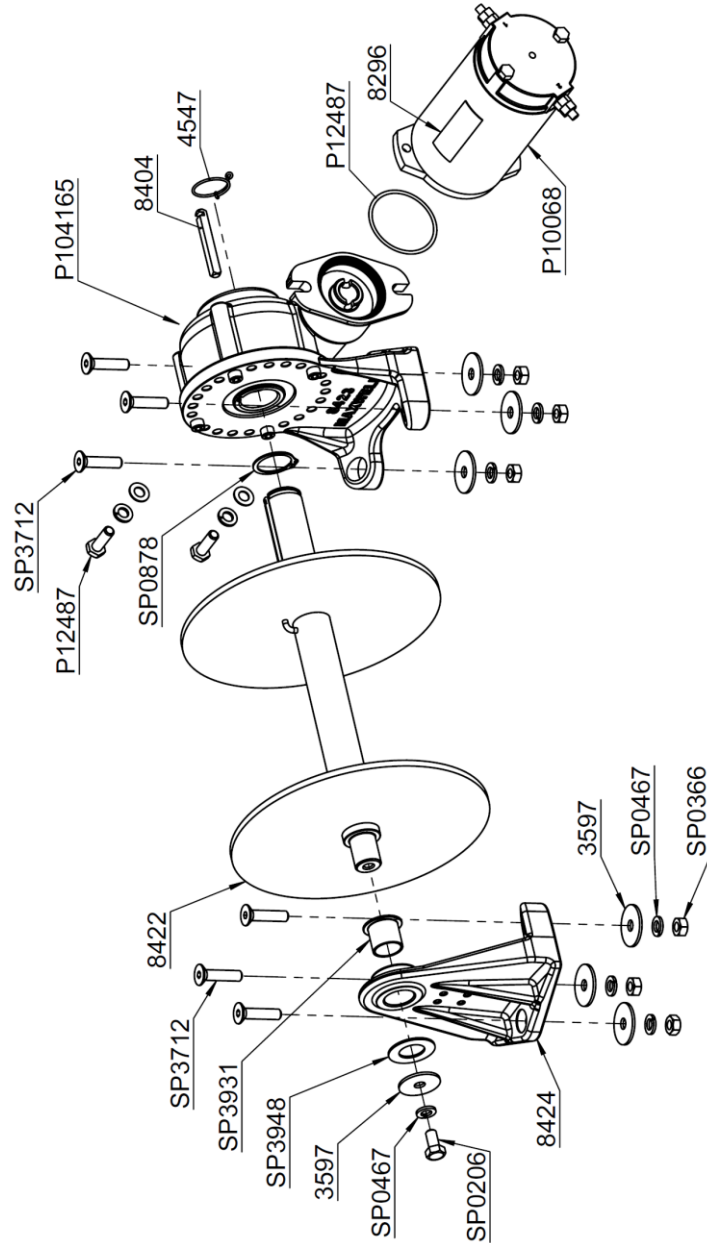

Copyright Maxwell Marine International

Rev.	Change	Made on	Des'Dwn	Checked
1.00	Initial issue	09/11/17	PC	GB
2.00	Change Drum Width 200 to 180.	22/01/18	Peter Chiu	GB

Sheet	Scale	Dwg Type	Sheet	Description	Pbv/Dwg No.
A4	1:5	pbv	1 of 2	Tasman 6-6 drum winch	P102876

File location: W:\Product Data\assemblies\P102000-P102999\P102876\_2.00\_Pbv\_TASMAN 6-6 drum winch

# APPENDIX C – DC Electric Wiring (TASMAN 8)

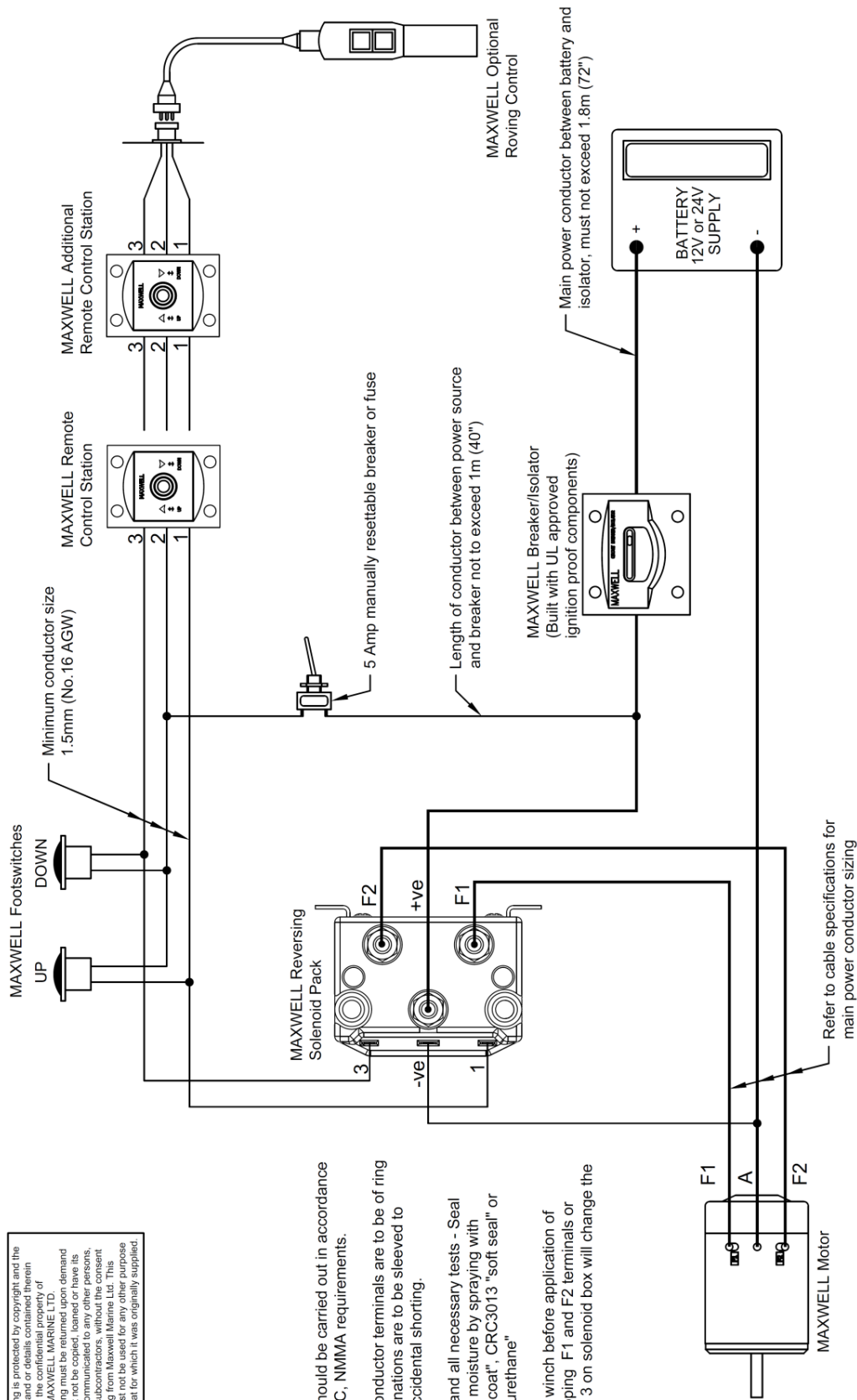

This drawing is protected by copyright and the design and details contained herein are the confidential property of MAXWELL MARINE LTD. This drawing must be returned upon demand and must not be copied, loaned or have its contents communicated to any other persons, including subcontractors, without the consent in writing from Maxwell Marine Ltd. This drawing must be for the specific purpose other than that for which it was originally supplied.

**Note:**

- All installations should be carried out in accordance with USCG, ABYC, NMMA requirements.
- All main power conductor terminals are to be of ring type and all terminations are to be sleeved to protect against accidental shorting.
- After installation and all necessary tests - Seal terminals against moisture by spraying with CRC2403 "plasti-coat", CRC3013 "soft seal" or CRC2409 "clear urethane"
- Check rotation of winch before application of chain/rope. Swapping F1 and F2 terminals or connection 1 and 3 on solenoid box will change the rotation of winch.

Revision	Change	Made On	Des/Drawn	Checked	BVT/Dwg No.	Description	Assy No.
1.00	Initial Issue	22/3/2017	GB		N/A	Wiring Diagram - Typical For Series Wound Motors	P101868
					BVT View		
					N/A		
					Sheet Size	Scale	
					A4	NTS	
					Sheet 1 of 1		

# DC Electric Wiring (TASMAN 6)

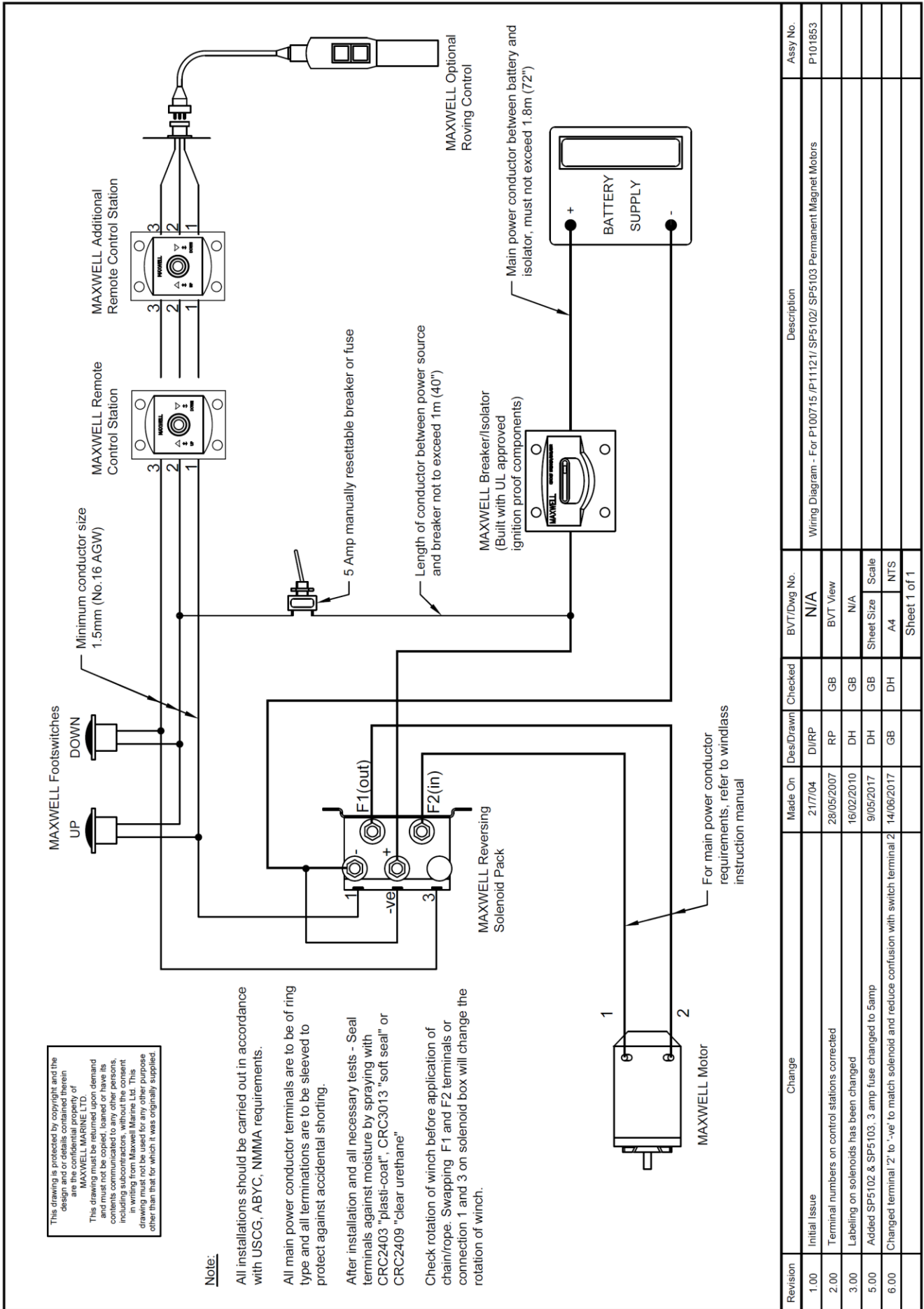

This drawing is protected by copyright and the design and/or details contained therein are the property of MAXWELL MARINE LTD. This drawing must be returned upon demand and must not be copied, loaned or have its contents communicated to any other persons including subcontractors, without the consent in writing from Maxwell Marine Ltd. This drawing must not be used for any other purpose other than that for which it was originally supplied.

Revision	Change	Made On	Des/Drawn	Checked	BVT/Dwg No.	Description	Assy No.
1.00	Initial Issue	21/7/04	D/IRP		N/A	Wiring Diagram - For P100715 /P11121/ SP5102/ SP5103 Permanent Magnet Motors	P101853
2.00	Terminal numbers on control stations corrected	28/05/2007	RP	GB	BVT View		
3.00	Labeling on solenoids has been changed	16/02/2010	DH	GB	N/A		
5.00	Added SP5102 & SP5103, 3 amp fuse changed to 5amp	9/05/2017	DH	GB	Scale		
6.00	Changed terminal 2' to '-ve' to match solenoid and reduce confusion with switch terminal 2	14/06/2017	GB	DH	A4	NTS	
						Sheet 1 of 1	

APPENDIX C – TASMAN 8 Mounting template (NOT TO SCALE)

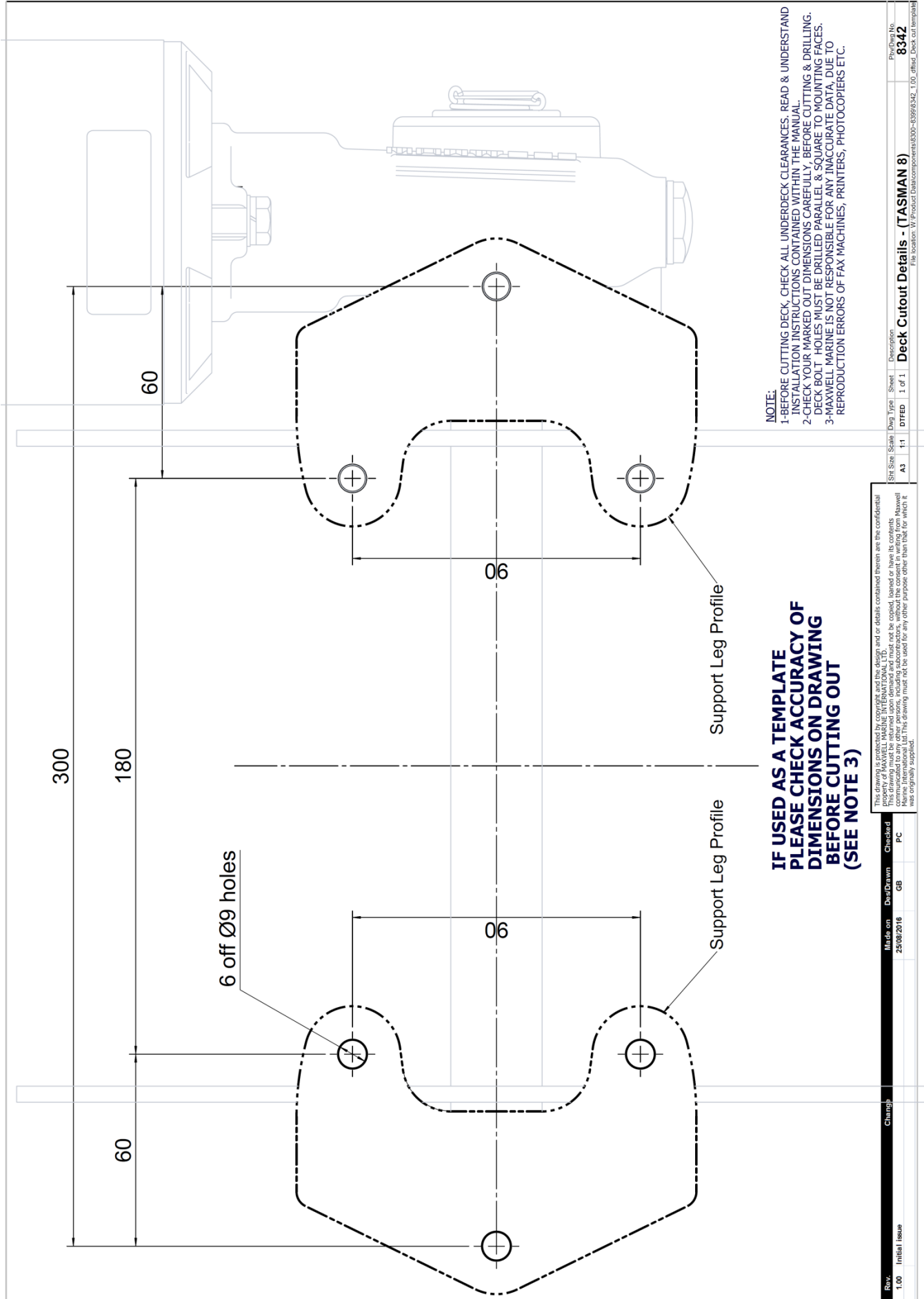

**NOTE:**  
 1-BEFORE CUTTING DECK, CHECK ALL UNDERDECK CLEARANCES. READ & UNDERSTAND INSTALLATION INSTRUCTIONS CONTAINED WITHIN THE MANUAL.  
 2-CHECK YOUR MARKED OUT DIMENSIONS CAREFULLY, BEFORE CUTTING & DRILLING. DECK BOLT HOLES MUST BE DRILLED PARALLEL & SQUARE TO MOUNTING FACES.  
 3-MAXWELL MARINE IS NOT RESPONSIBLE FOR ANY INACCURATE DATA, DUE TO REPRODUCTION ERRORS OF FAX MACHINES, PRINTERS, PHOTOCOPIERS ETC.

**IF USED AS A TEMPLATE  
 PLEASE CHECK ACCURACY OF  
 DIMENSIONS ON DRAWING  
 BEFORE CUTTING OUT  
 (SEE NOTE 3)**

This drawing is protected by copyright and the design and/or details contained therein are the confidential property of Maxwell Marine Pty Ltd. It is to be used for the specific purpose for which it was originally supplied. This drawing must not be used for any other purpose other than that for which it was originally supplied.

Rev.	Initial Issue	Change	Made on	Des/Drawn	Checked
1.00	Initial Issue		25/08/2016	CB	PC

Std Size	Scale	Draw Type	Sheet	Description	Pro/Draw No.
A3	1:1	DTFED	1 of 1	Deck Cutout Details - (TASMAN 8)	8342

File location: W:\Product Data\Accessories\AS300-AS300\8342\_1.00\_dtfed\_Deck cut template

# TASMAN 6 Mounting template (NOT TO SCALE)

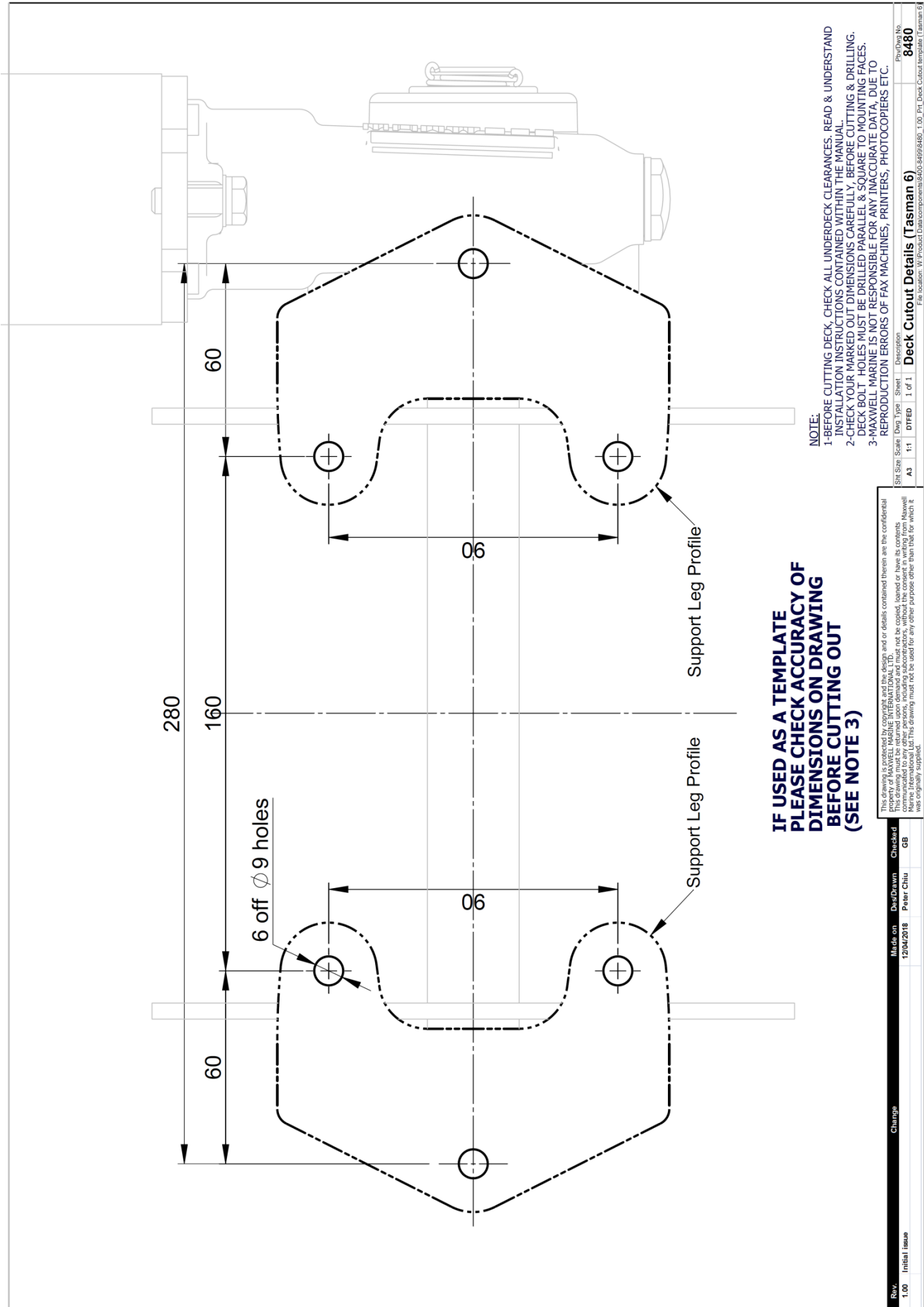

**NOTE:**  
 1-BEFORE CUTTING DECK, CHECK ALL UNDERDECK CLEARANCES, READ & UNDERSTAND INSTALLATION INSTRUCTIONS CONTAINED WITHIN THE MANUAL.  
 2-CHECK YOUR MARKED OUT DIMENSIONS CAREFULLY, BEFORE CUTTING & DRILLING. DECK BOLT HOLES MUST BE DRILLED PARALLEL & SQUARE TO MOUNTING FACES.  
 3-MAXWELL MARINE IS NOT RESPONSIBLE FOR ANY INACCURATE DATA, DUE TO REPRODUCTION ERRORS OF FAX MACHINES, PRINTERS, PHOTOCOPIERS ETC.

**IF USED AS A TEMPLATE  
 PLEASE CHECK ACCURACY OF  
 DIMENSIONS ON DRAWING  
 BEFORE CUTTING OUT  
 (SEE NOTE 3)**

Rev.	1.00	Initial Issue
Change		
Made on	12/04/2018	Patric Citru
Drawn		GB
Checked		
This drawing is protected by copyright and the design and/or details contained therein are the confidential property of MAXWELL MARINE INTERNATIONAL LTD. It may not be copied, loaned or taken in any form, or communicated to any other persons, including subcontractors, without the consent in writing from Maxwell Marine International Ltd. This drawing must not be used for any other purpose other than that for which it has originally prepared.		
Sheet	1 of 1	
Description	Deck Cutout Details (Tasman 6)	
Part No	8480	
File location: W:\Product Data Components\8480-1.00_Prt_Deck_Cutout_Template (Tasman 6)		

## LIMITED WARRANTY

**Warranty:** VETUS-Maxwell APAC Ltd (Maxwell) provides a three year limited warranty on all windlasses for pleasure boat usage, and a one year limited warranty for those systems used on commercial or charter vessels. Warranty, service and parts are available around the world. Contact your nearest Maxwell office for a complete list of service centres and distributors.

**This warranty is subject to the following conditions and limitations:**

1. This Warranty will be null and void if
  - a. there is any neglect or failure to properly maintain and service the products.
  - b. the products are serviced, repaired or maintained improperly or by unauthorised persons.
  - c. loss or damage is attributed to any act, matter or omission beyond the reasonable control of Maxwell or the purchaser.
2. Maxwell's liability shall be limited to repair or replacement (as determined by Maxwell) of the goods or parts defective in materials or workmanship.
3. Determination of the suitability of the product and the materials for the use contemplated by the buyer is the sole responsibility of the buyer, and Maxwell shall have no responsibility in connection with such suitability.
4. Maxwell shall not be liable for any loss, damages, harm or claim attributed to:
  - a. use of the products in applications for which the products are not intended.
  - b. corrosion, wear and tear or improper installation.
  - c. improper use of the product.
5. This Warranty applies to the original purchaser of the products only. The benefits of the Warranty are not transferable to subsequent purchasers.
6. Maxwell shall not be responsible for shipping charges or installation labour associated with any warranty claims.
7. There are no warranties of merchantability, fitness for purpose, or any other kind, express or implied, and none shall be implied by law. If any such warranties are nonetheless implied by law for the benefit of the customer they shall be limited to a period of three years from the original purchase by the user.
8. Maxwell shall not be liable for consequential damages to any vessel, equipment, or other property or persons due to use or installation of Maxwell equipment.
9. This Warranty sets out your specific legal rights allowed by Maxwell; these may be varied by the laws of different countries. In addition, the purchaser may also have other legal rights which vary from country to country.
10. To make a claim under this Warranty, contact your nearest Maxwell office or distributor. Proof of purchase and authorisation from Maxwell will be required prior to any repairs being attempted.

To be eligible for warranty protection, please either complete the form below at the time of purchase and return it to the appropriate retailer or supplier of the goods, or fill out the electronic warranty form on our website, [www.maxwellmarine.com](http://www.maxwellmarine.com)

**Purchaser**

Name:

Address:

Telephone:

Facsimile

**Supplier / Dealer**

Name:

Address:

Telephone:

Facsimile

**Windlass Model**

**Serial Number**

Date of Purchase

Boat Type

Windlasses Supplied

With boat

Fitted by boat yard/dealer

Purchased from dealer/chandler

Name

L.O.A.

Built by





